

COLUMBUS PROJECT

MIRROR BLANK 8.4 m diam f/1.14

*STRESS CONCENTRATION FACTORS DUE TO VENTILATION HOLES
NEAR INNER EDGE*

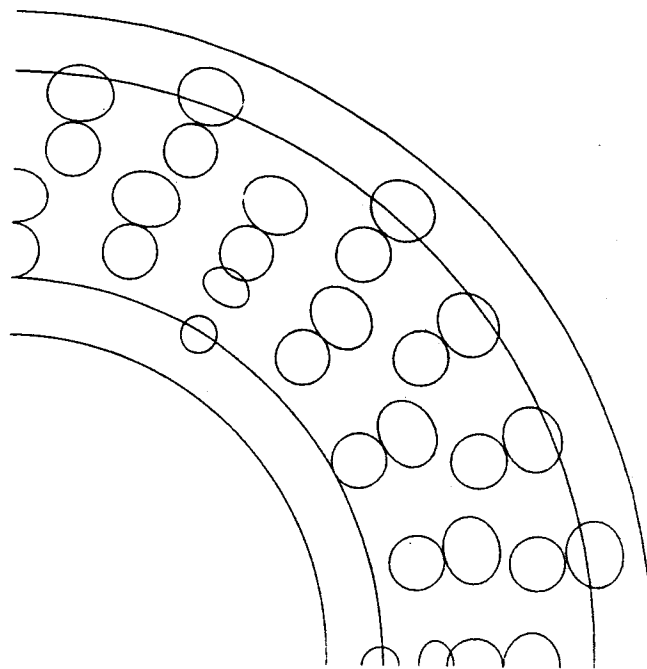

INDEX

1.	INTRODUCTION	pag. 3
2.	CODE USED	pag. 3
3.	MODELS USED	pag. 4
4.	RESULTS	pag. 4

1. INTRODUCTION

The original design of primary mirrors of Columbus telescope foresees some ventilation holes, having 88.9 mm diameter, placed approximately at 40 mm from the inner edge of the back plate (see fig. 1).

This zone, in some handling schemes is subject to tensile stresses in tangential direction. Obviously, being near to a free edge, and since no loads are applied to it, radial stresses are null.

In all the stress analyses performed just now we used a stress concentration factors = 4. in order to take into account the effects of these holes.

It is a value computed for a straight edge and with a different hole pattern (see rep. N. 127 pag. 9). So it is a value valid for some zones of the external mirror edge but at the inner edge the ventilation hole pattern is very different from that considered and, moreover, the edge isn't straight.

There was the need to better estimate the stress concentration factor for this geometry/stress condition.

In order to reduce the man time necessary to appoint numerical model by means of Finite Element Method (FEM), we used, for such analyses, the Boundary Element Method (BEM).

2. CODE USED

The code used has been tested with some cases known in literature.

We performed also a comparison between the stress concentration factor computed for the crosspin holes in the ribs respectively by FEM and BEM.

We refer to cases I and IV (the rib height is not a meaningful parameter) of table A at pag 12 of Rep. N° 130.

In figure 2-a,2-b,2-c,2-d are reported:

- a- geometry and loads
- b- the mesh used with the BEM model
- c- the deformed shape
- d- the principal stress pattern obtained by means of BEM.

The stress concentration factor obtained by BEM is 3.09 that is 5% smaller than that obtained by means of FEM (3.25). On the other hand with BEM we used only 38 degrees of freedom instead of some thousands used for FEM.

Increasing a little the number of nodes along the crosspin hole BEM and FEM results coincide.

3. MODELS USED

The stress concentration factor K_e is defined as:

$$K_e = \frac{\sigma_{e,max}}{\sigma_{e,nom}}$$

where:

- the subscript "e" means that all the values are computed by means of linear elastic analyses.
- $\sigma_{e,max}$ is the maximum stress value.
- $\sigma_{e,nom}$ is the nominal stress value obtained from the numerical analyses on the global model, or in this report, by means of analyses of the lower plate without ventilation holes.

In figures 3 and 4 are reported the two models (Case A and Case B) respectively used in order to compute $\sigma_{e,nom}$ and $\sigma_{e,max}$.

Dimensions are reported in millimeters on the figures.

In order to generate tangential tensile stresses at the internal edge an unitary, radial, tensile load has been applied at the external edge (see fig. 3-4).

4. RESULTS

The elasticity theory states that the tangential stresses in case A (fig. 3) are:

$$\sigma_t = \frac{q}{s} \times \frac{r_o^2}{r_o^2 - r_i^2} \times \left[1 + \frac{r_i^2}{r^2} \right]$$

where:

- r = radial coordinate
- r_o = outer radius = 960 mm
- r_i = inner radius = 520 mm
- q = load (per length unit) = $1. \frac{N}{mm}$
- s = thickness = 1. mm

So we have:

$$\sigma_t = 2.8305 \text{ MPa} = \sigma_{e,nom}$$

This value is exactly coincident with that obtained by BEM. In figures 5-6 are reported the deformed shape and the principal stress pattern obtained in such a case.

The deformed shape and the principal stress pattern obtained in case B (back plate with ventilation holes) are reported in figures 7-8. The maximum tensile stress occurs at the boundary of the ventilation holes nearest to the inner edge, its value is:

$$\sigma_{e,max} = 12.2 \text{ MPa}$$

So we can affirm that for the original design the stress concentration factors is:

$$K_e = \frac{12.2}{2.83} = 4.3 \text{ that is } 8 \% \text{ greater than the value used for the checks performed in the past.}$$

In figures 9 is reported a proposal in order to reduce the diameter of the holes nearest to the inner edge. For these holes the diameters decreases from 88.9 to 60 mm.

In figures 10-11 are reported the deformed shape and the principal stress pattern obtained in this case.

The maximum tensile stress is now:

$$\sigma_{e,max} = 9.3 \text{ MPa}$$

and the stress concentration factor becomes:

$$K_e = \frac{9.3}{2.83} = 3.28$$

So the change suggested permit to 24% reduce the stress concentration factor.

BCV

progetti s.r.l.

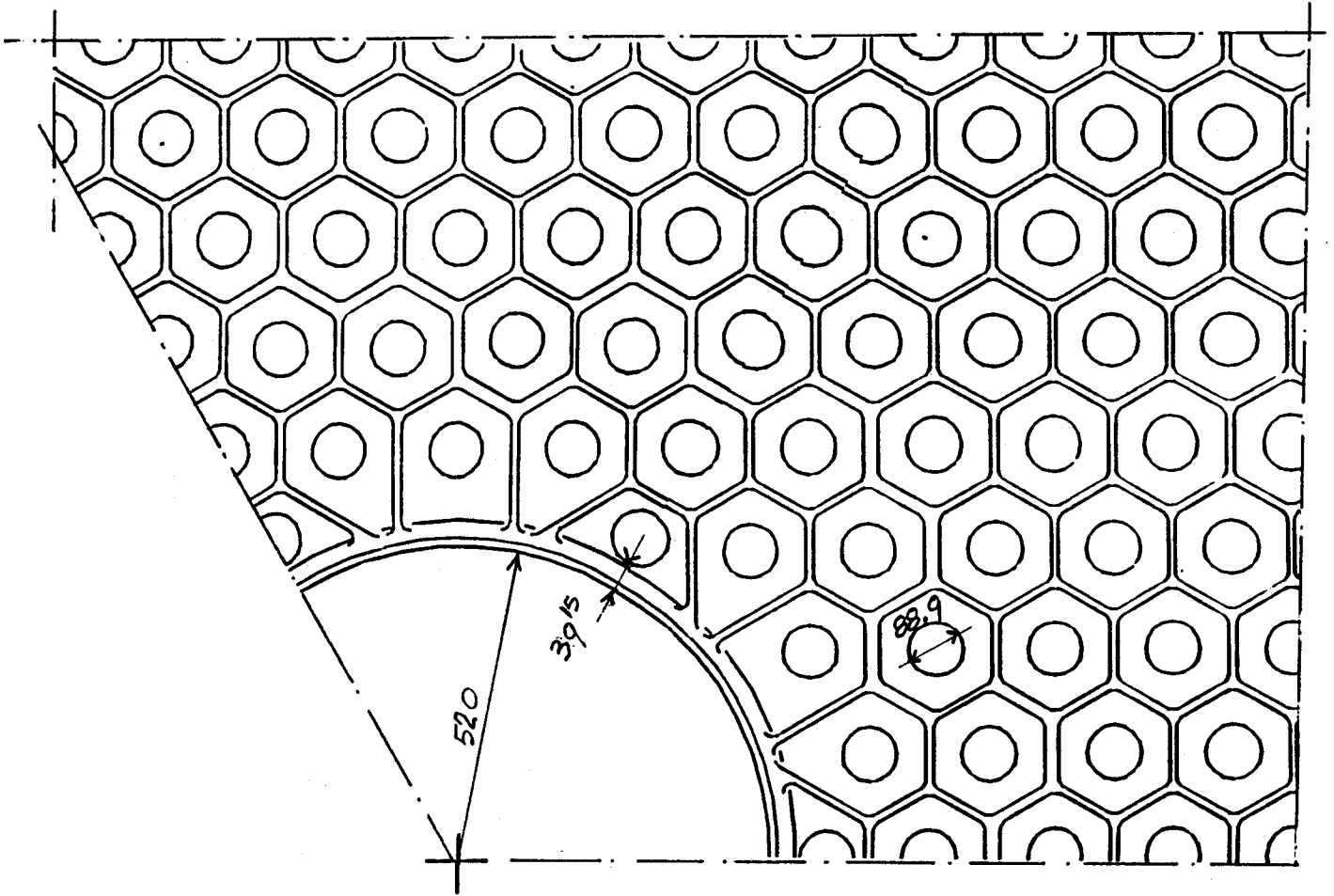

figure 1

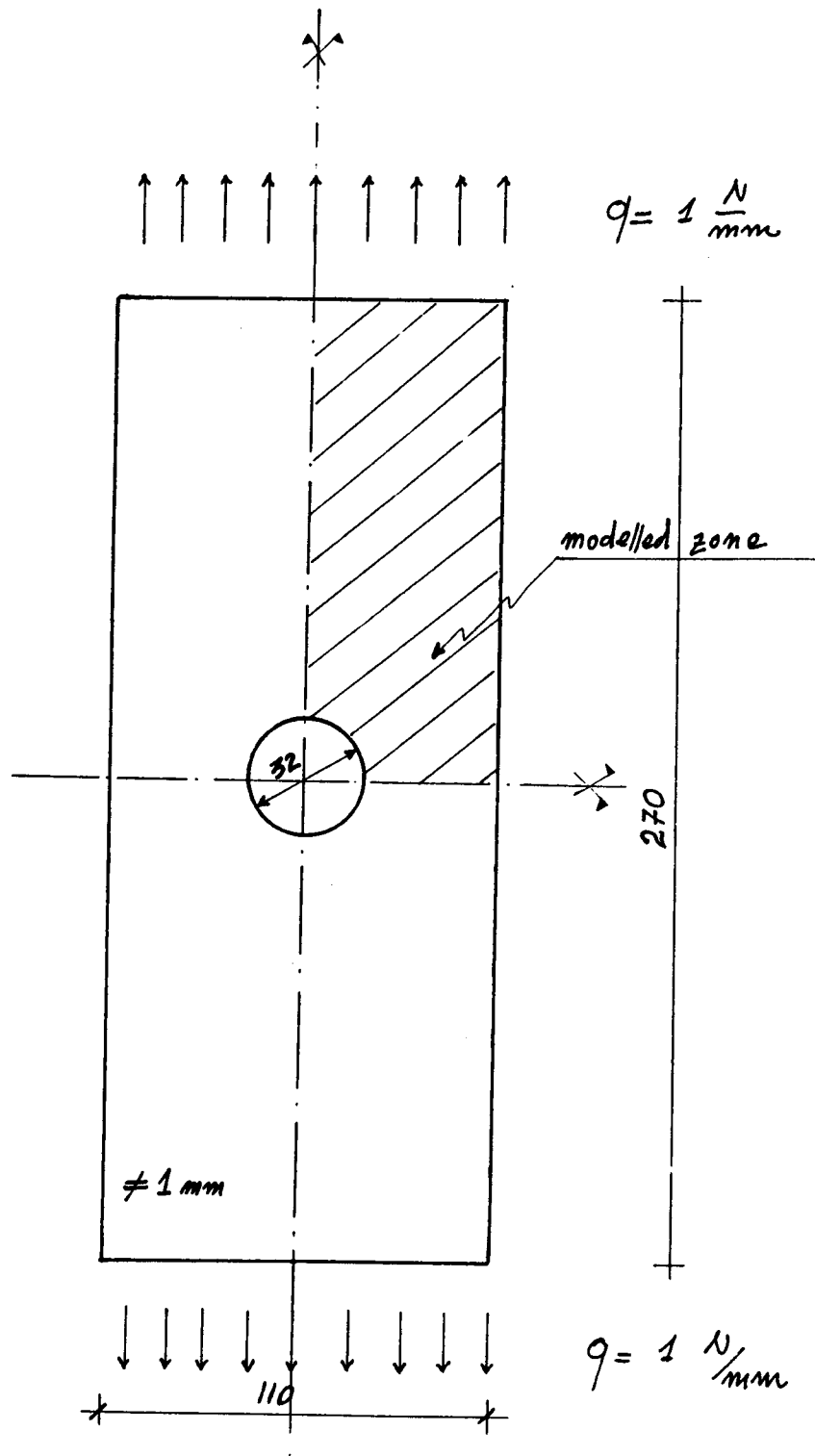

figure 2-a

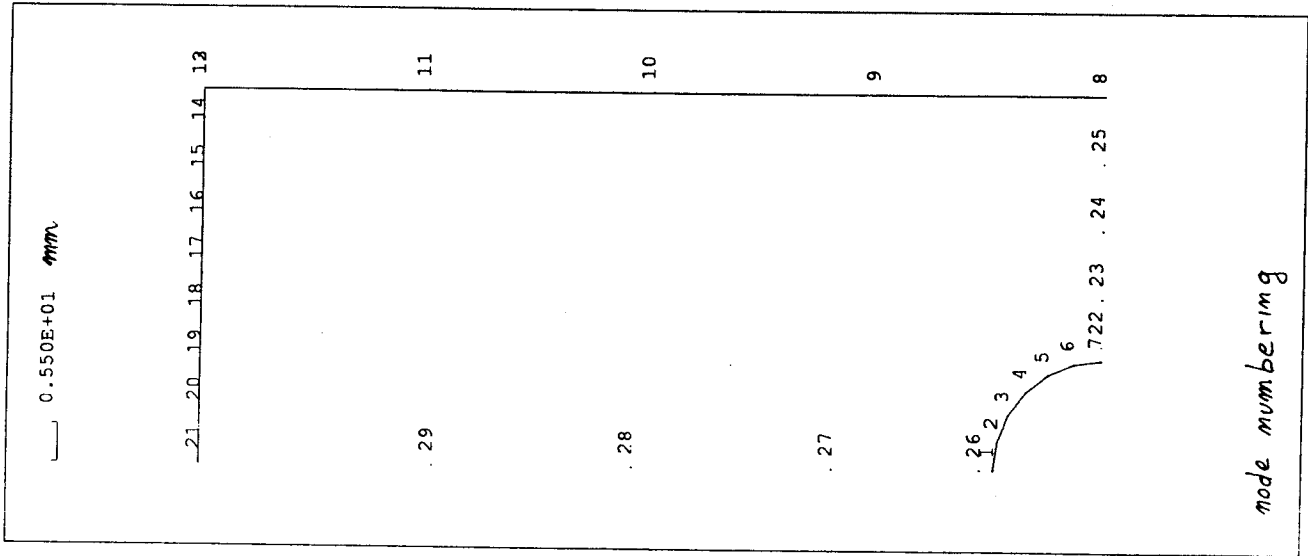

Fig. 2-b

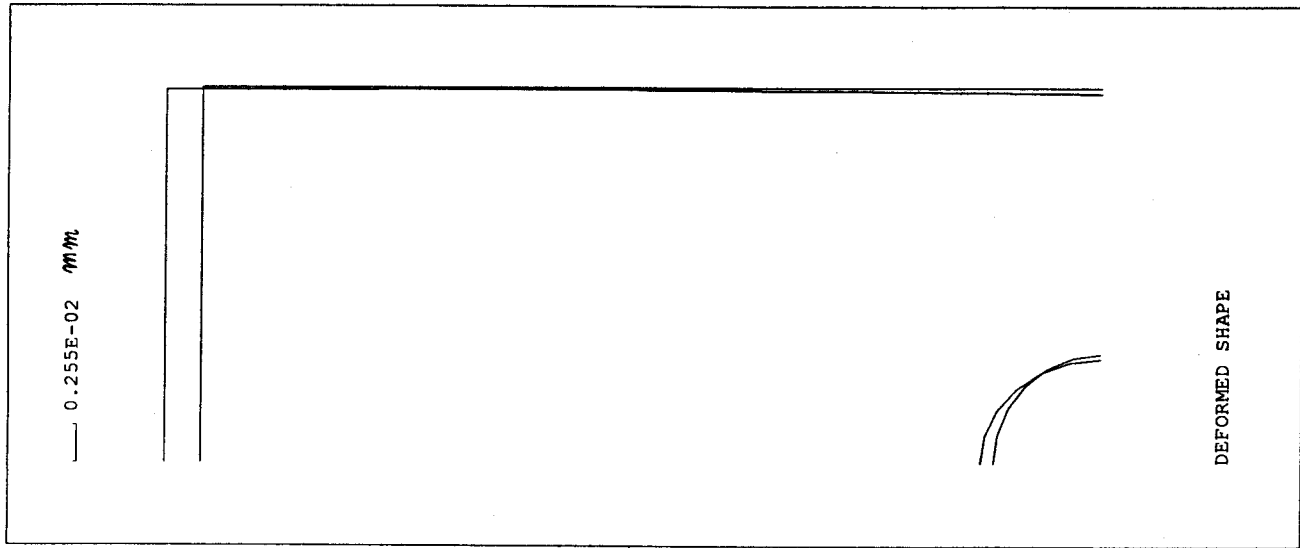

Fig. 2-c

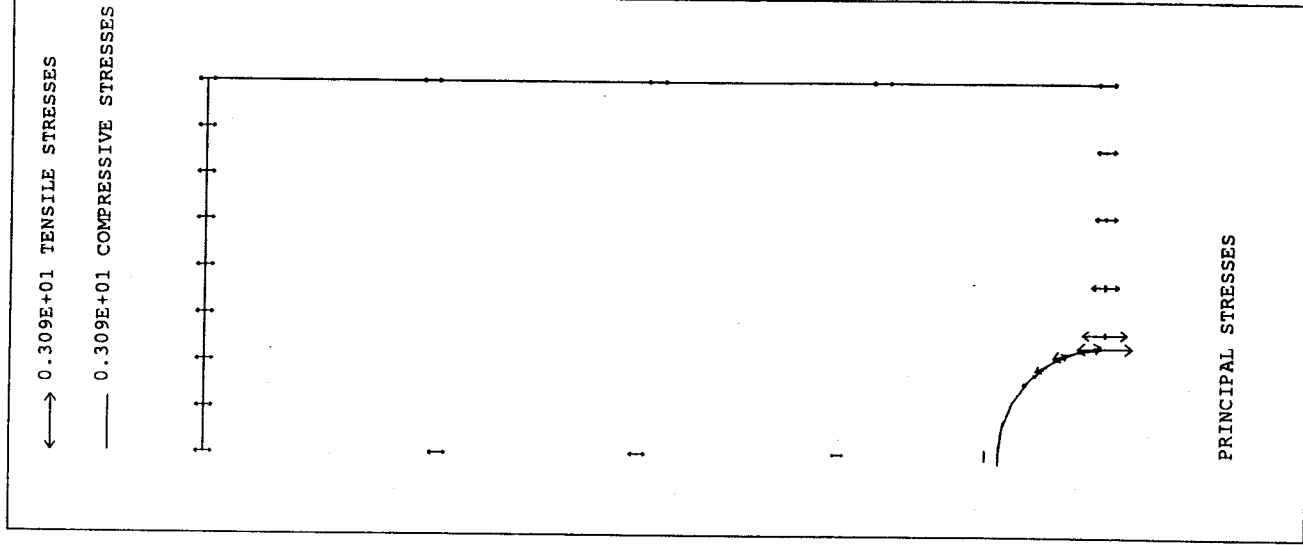

Fig. 2-d

CASE Δ

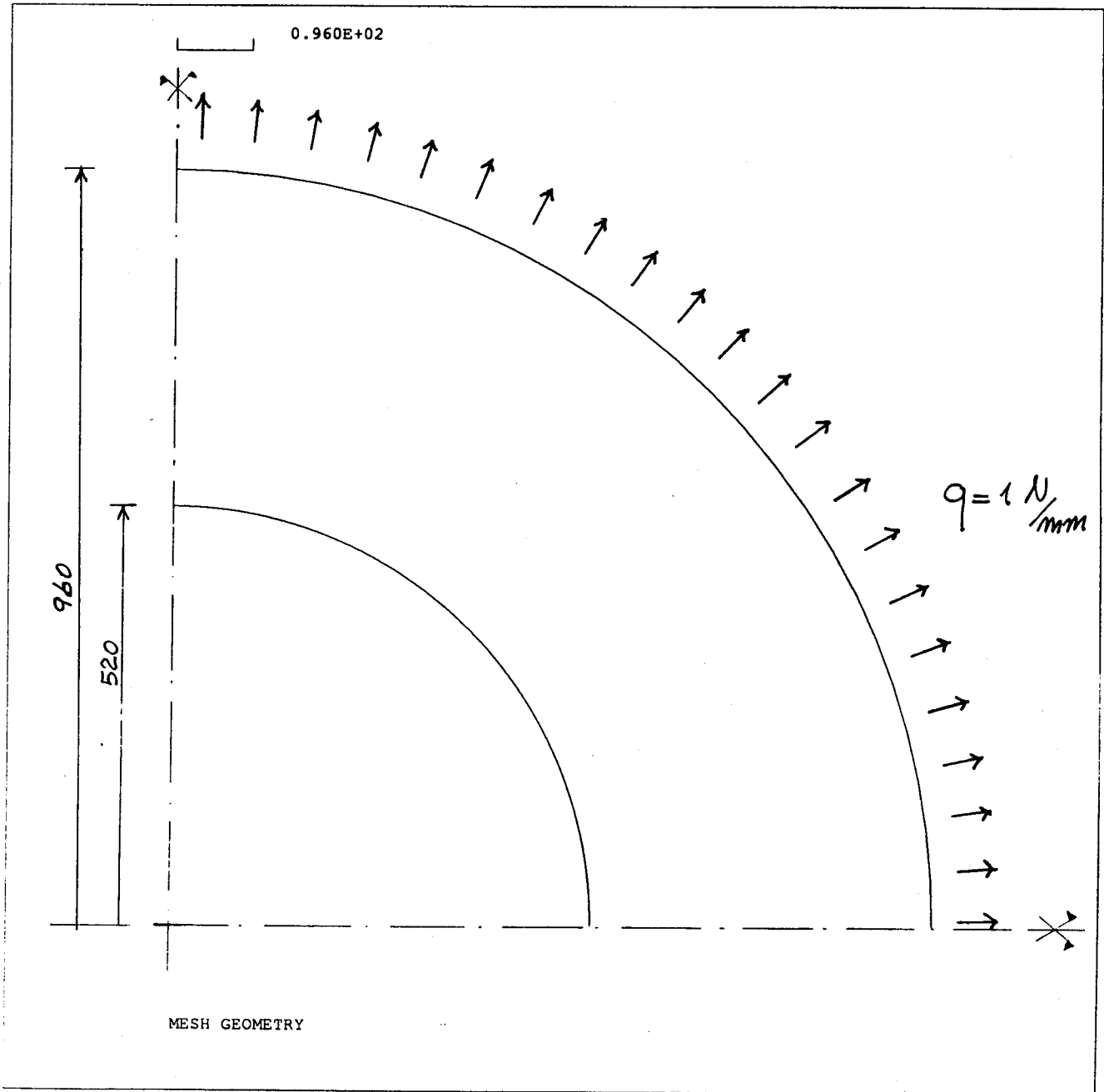

fig. 3

CASE B

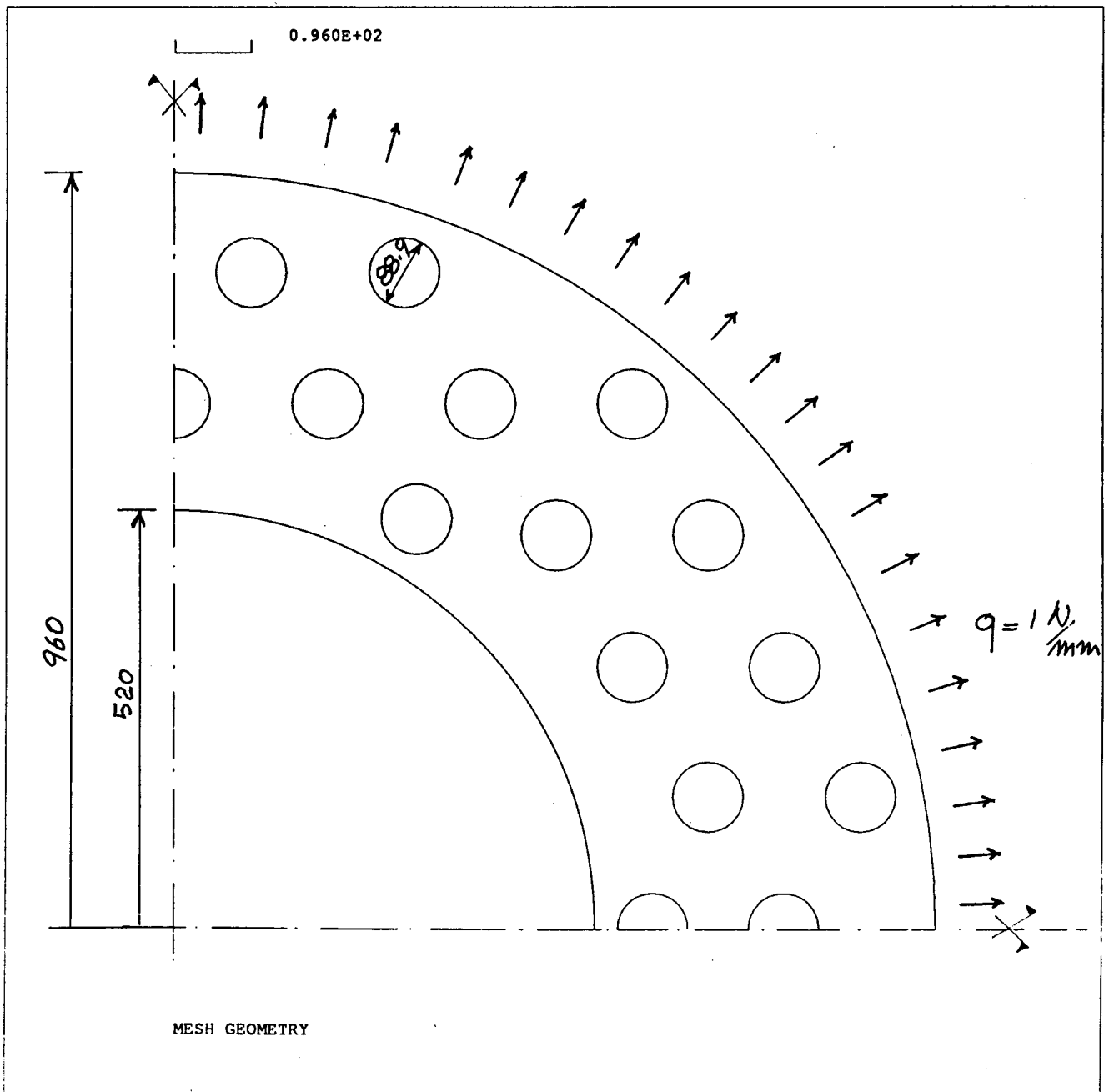

Fig. 4

CASE Δ

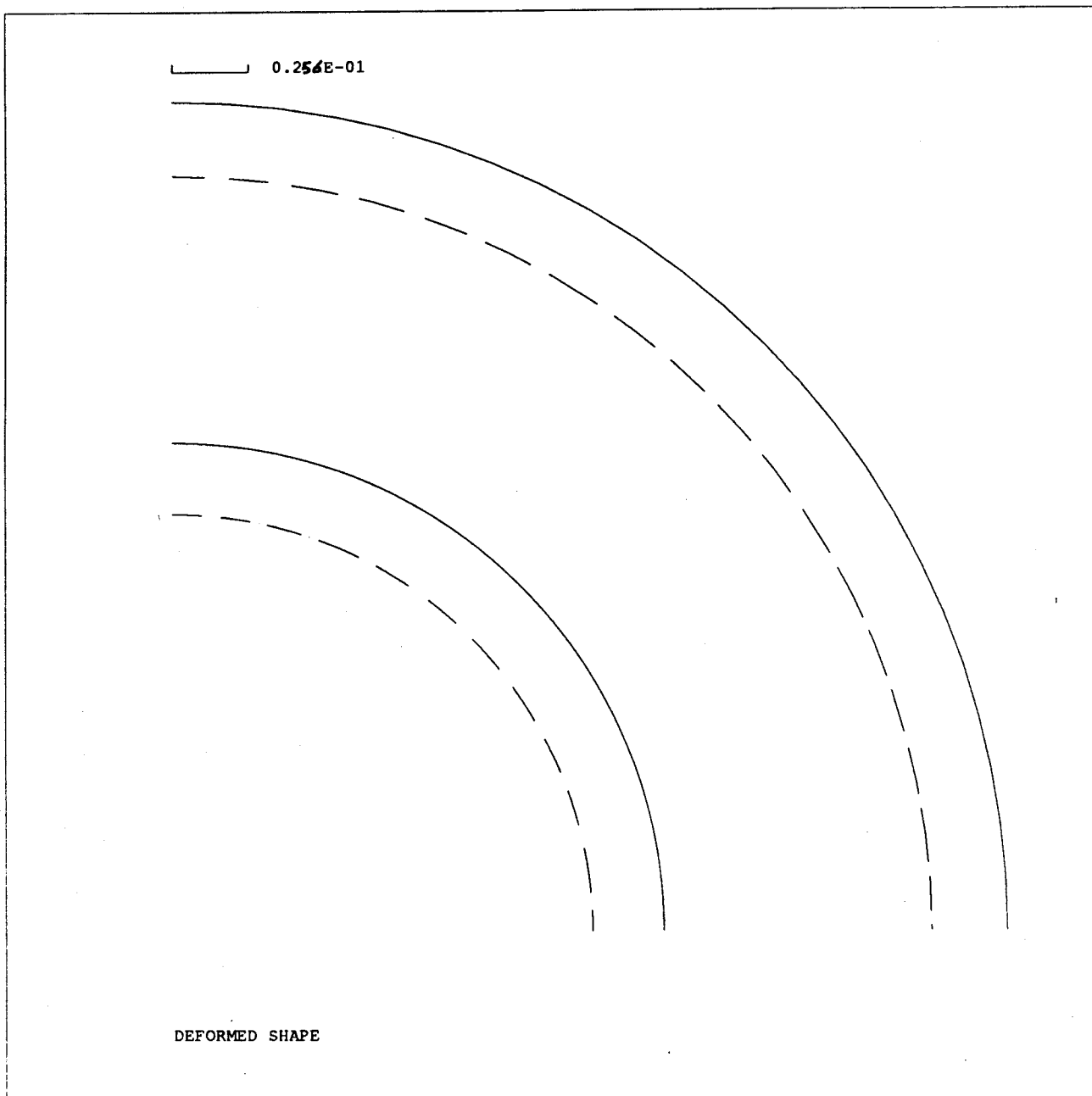

Fig. 5

CASE A

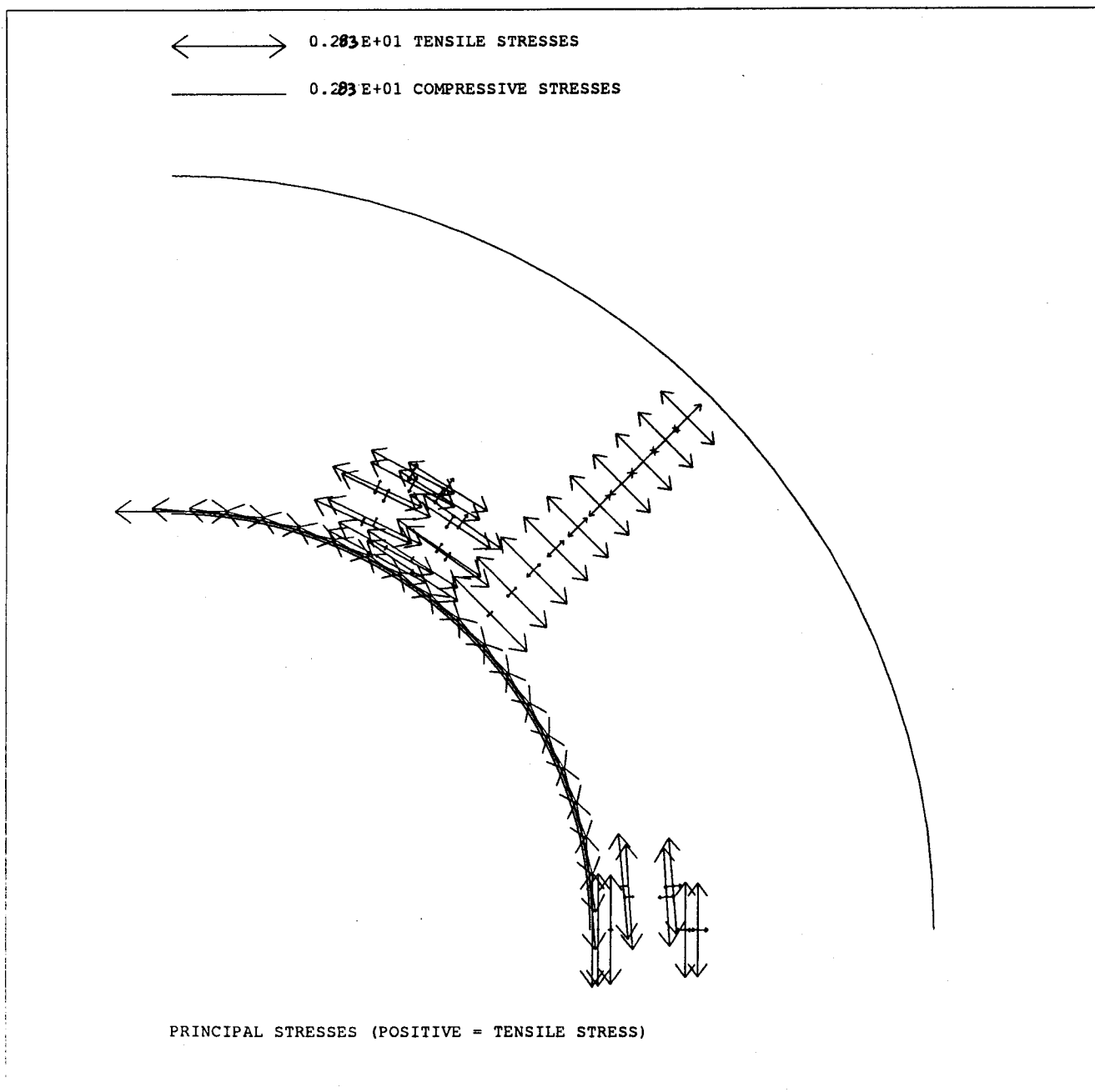
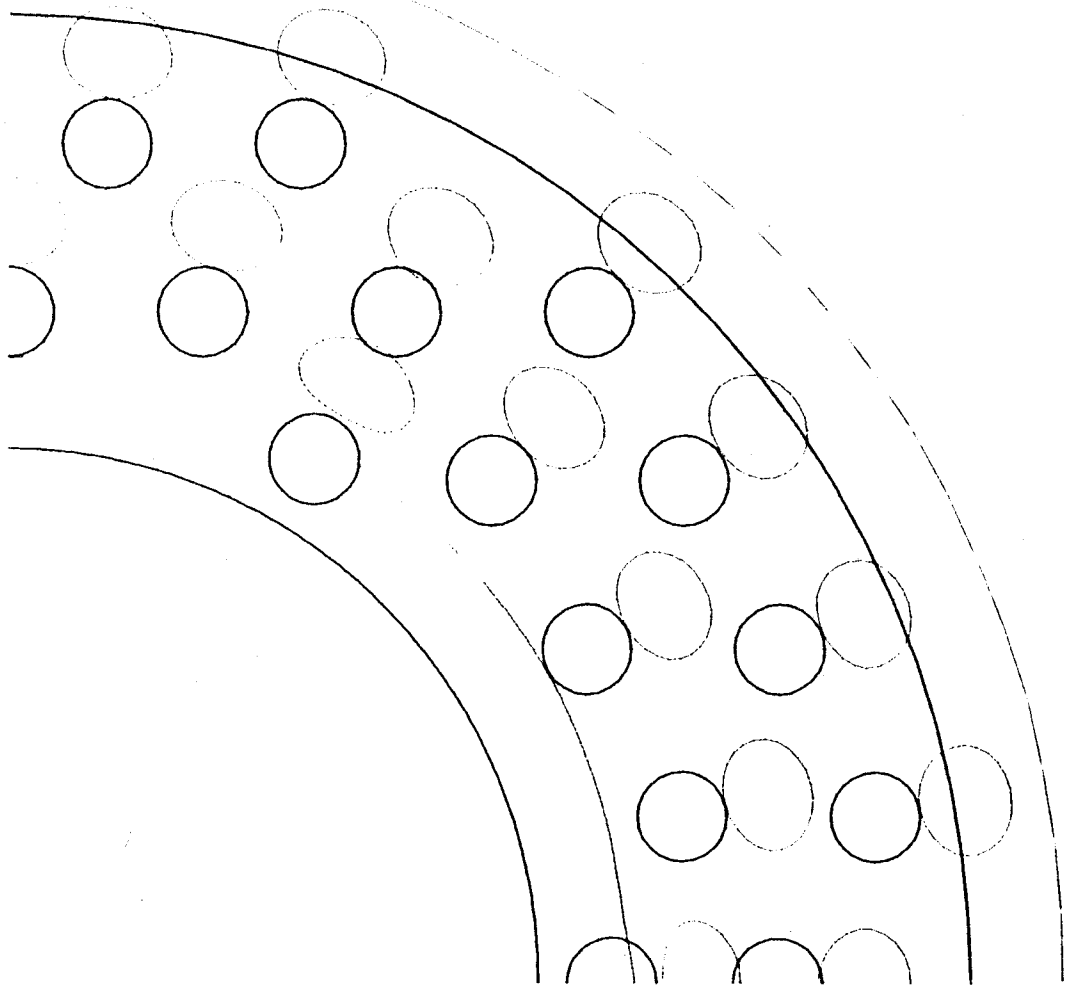

fig. 6

┌ 0.413 E-01



DEFORMED SHAPE

fig. 7

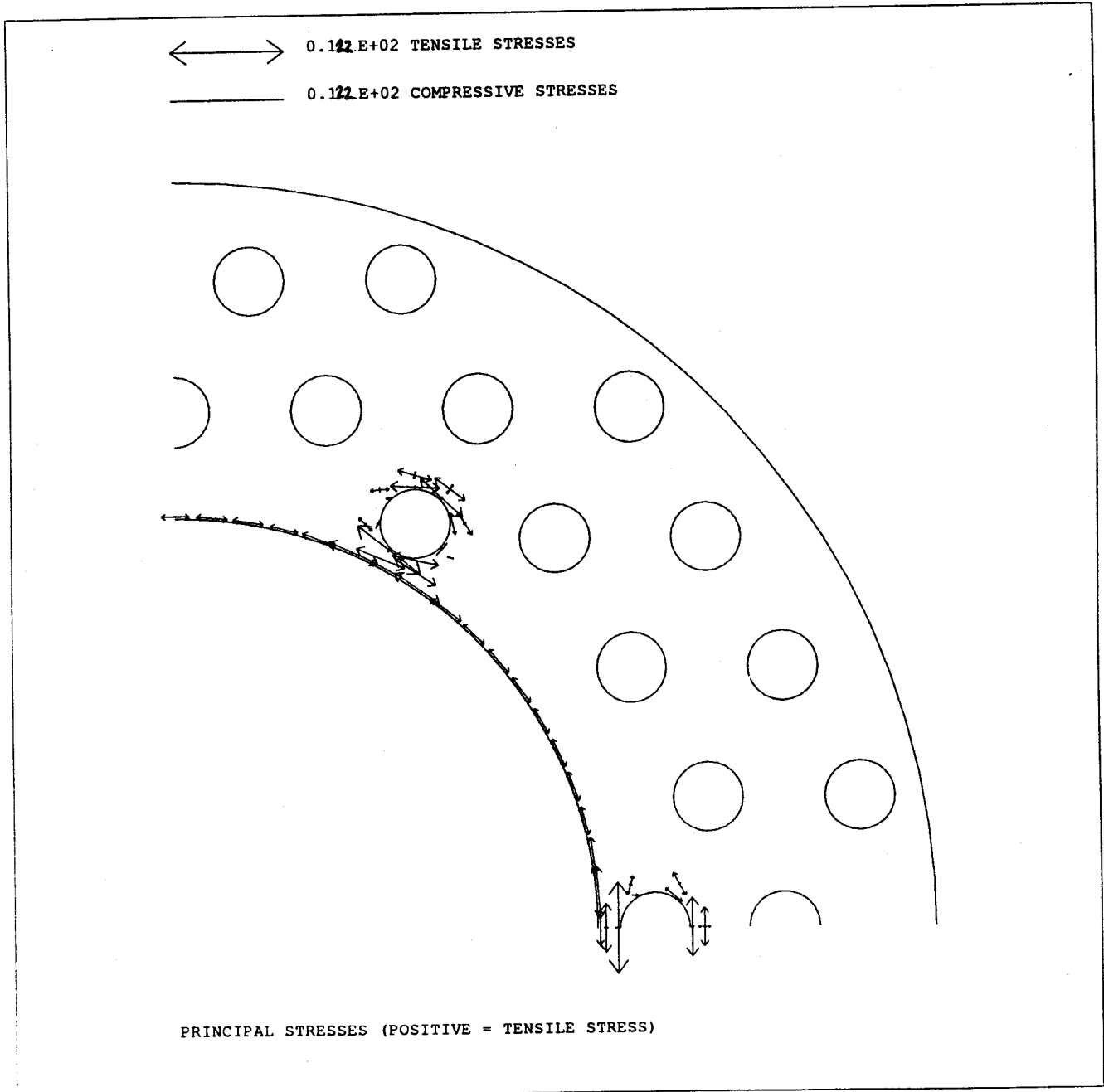

Fig. 8

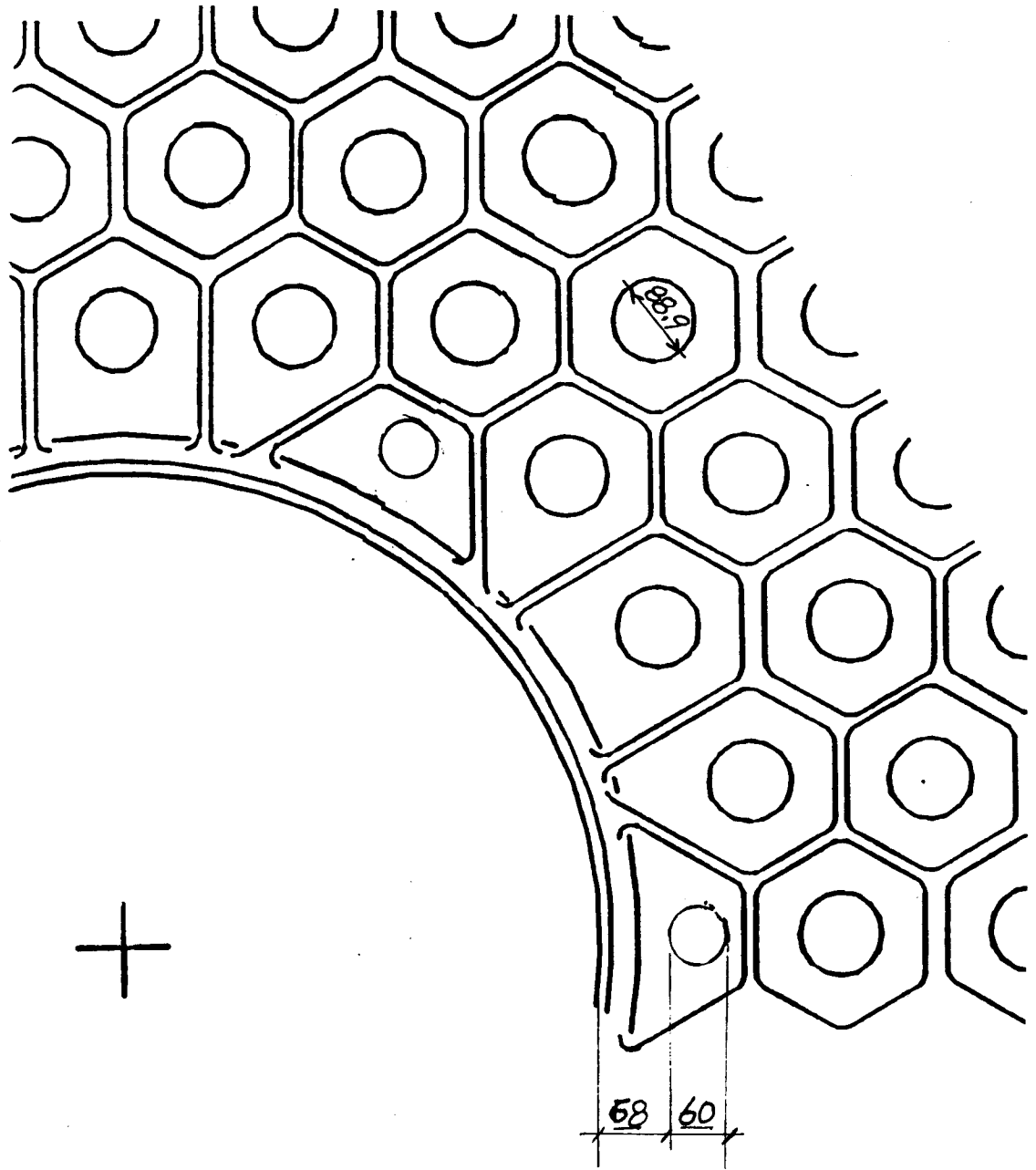
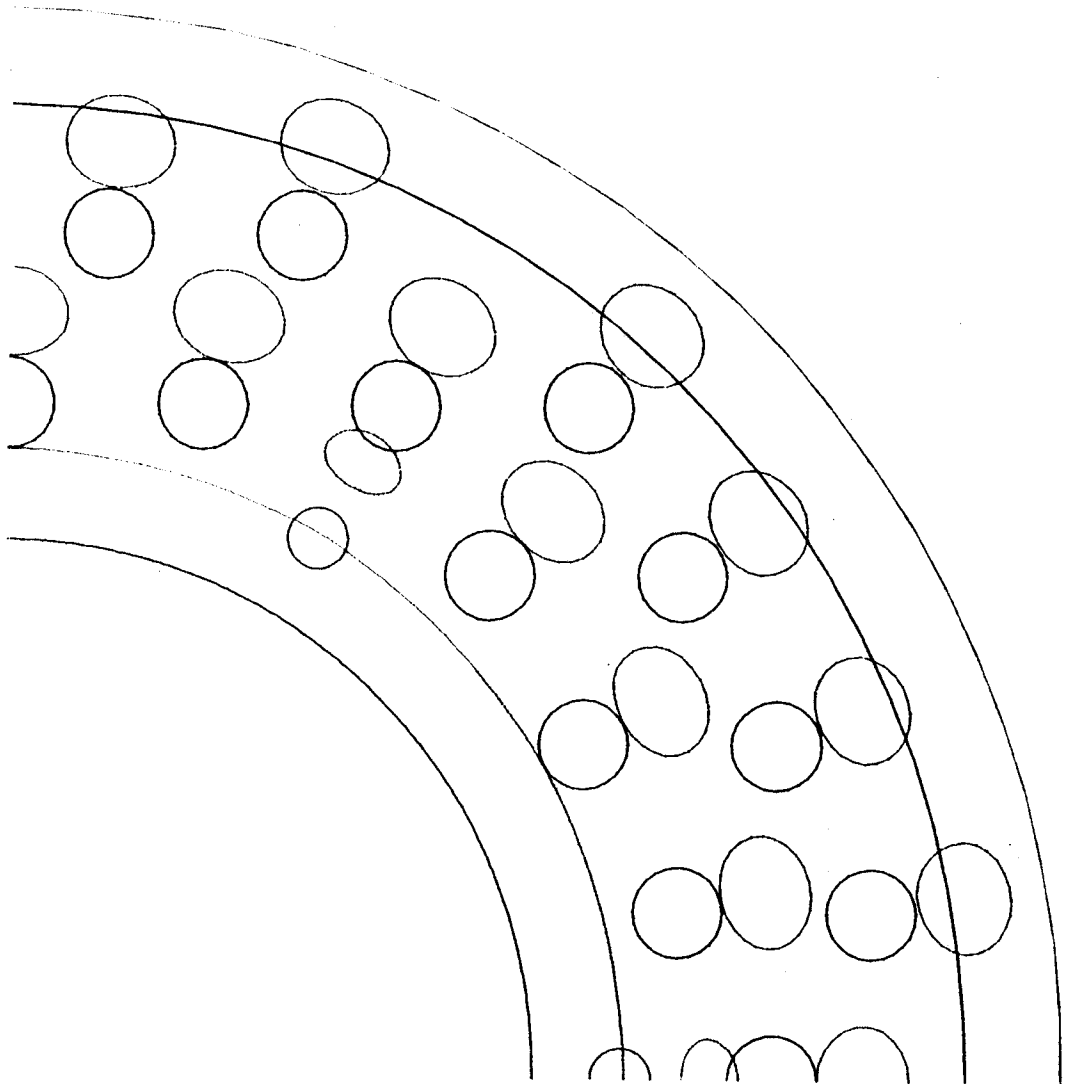

fig. 9

┌ 0.387 E-01



DEFORMED SHAPE

fig. 10

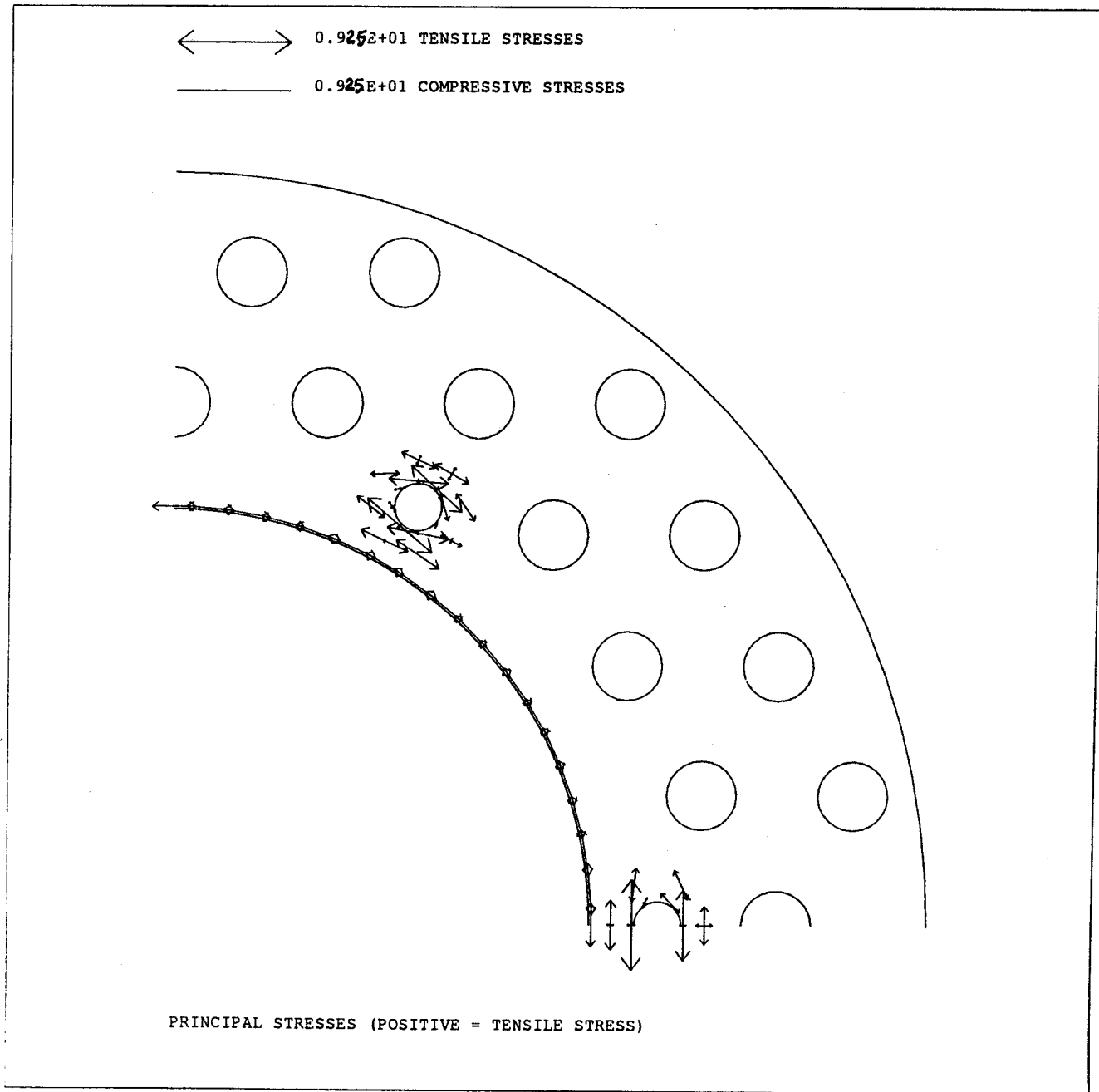

Fig. 11